

Rev	Date	Modified by	Description
A0	2023		

## Product Specifications

### Fiber Switch

#### Features

- In conformity to IEEE802.3 10base-T, IEEE802.3u 100 base-TX/FX, IEEE802.3ab 1000 base-T, IEEE802.3z,1000base-SX/LX, IEEE802.1a, IEEE802.1PQ0S, IEEE802.1d Spanning Tree.
- Hot Plug-gable & Wall-Mountable.  
Stable performance more than 50thousand hours with fault-free.
- Unique IC solution applied.  
Supports 10/100Mbps and 10/100/1000M full/half duplex, easy upgrades.
- Auto MDI/MDI-X.
- Auto Negotiation.
- Support flow control.
- Stable performance more than 50 thousands hours with fault-free.
- In conformity with safety code of FCC, CE and RoHS.

#### Applications

- Extend your Ethernet connection up to 0~120km away using fiber optics
- Creates an economical Ethernet-fiber/copper-fiber link for connecting remote sub-networks to larger fiber optic networks/backbones
- Converts Ethernet to fiber, fiber to copper/Ethernet, ensuring optimum network scalability for connecting two or more Ethernet network nodes (e.g. connecting two buildings on the same campus)
- Designed to provide high-speed bandwidth for demanding large scale work groups that require expansion of Gigabit Ethernet Network

#### Description

The fiber switches are unmanageable,when convert transmission,all ports share the same data. They can extend the network transmission from 100m to 120km and can realize the interconnection between motherboard server, Repeaters, hubs, switches, terminal.Plug and play design makes easy installation, no on-site adjustment. Operation status can be monitored through a set of Diagnostic LED.

## Specifications

Optical Interface	Connector	1x9 SC/FC/ST
	Data Rate	100Mbps, 1000Mbps
	Duplex Mode	Full duplex
	Fiber	MM 50/125um,62.5/125um SM 9/125um
	Distance	100Mbps: MM 5km,SM 5/25/40/60/80/100/120km 1000Mbps: MM 550m/5km,SM 5/20/40/60/80km
	Wavelength	MM 850nm,1310nm SM 1310nm,1550nm WDM Tx1310/Rx1550nm(A side),Tx1550/Rx1310nm(B side) WDM Tx1490/Rx1550nm(A side),Tx1550/Rx1490nm(B side)
UTP Interface	Connector	RJ45
	Data Rate	10/100Mbps, 10/100/1000Mbps
	Duplex Mode	Half/full duplex
	Cable	Cat5,Cat6
Power Input	Adapter Type	DC5V
	Power Built-in Type	AC100~240V
Power Consumption		<3W
Temperature		0~50°C Operating; -40~70°C Storage
Humidity		5~95%(no condensing)
MTBF		≥10.0000h
Certification		CE,FCC,RoHS

# System Design

## 1. For Networking

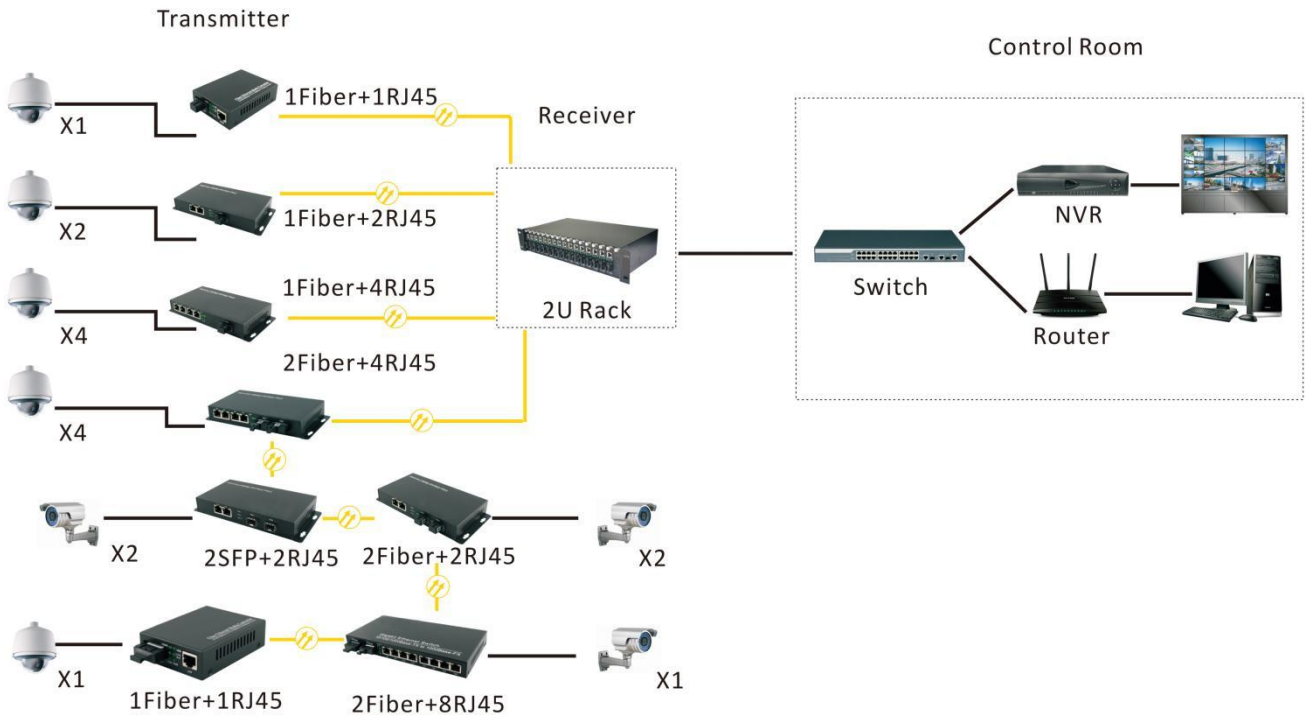

## 2. For CCTV Surveillance Security

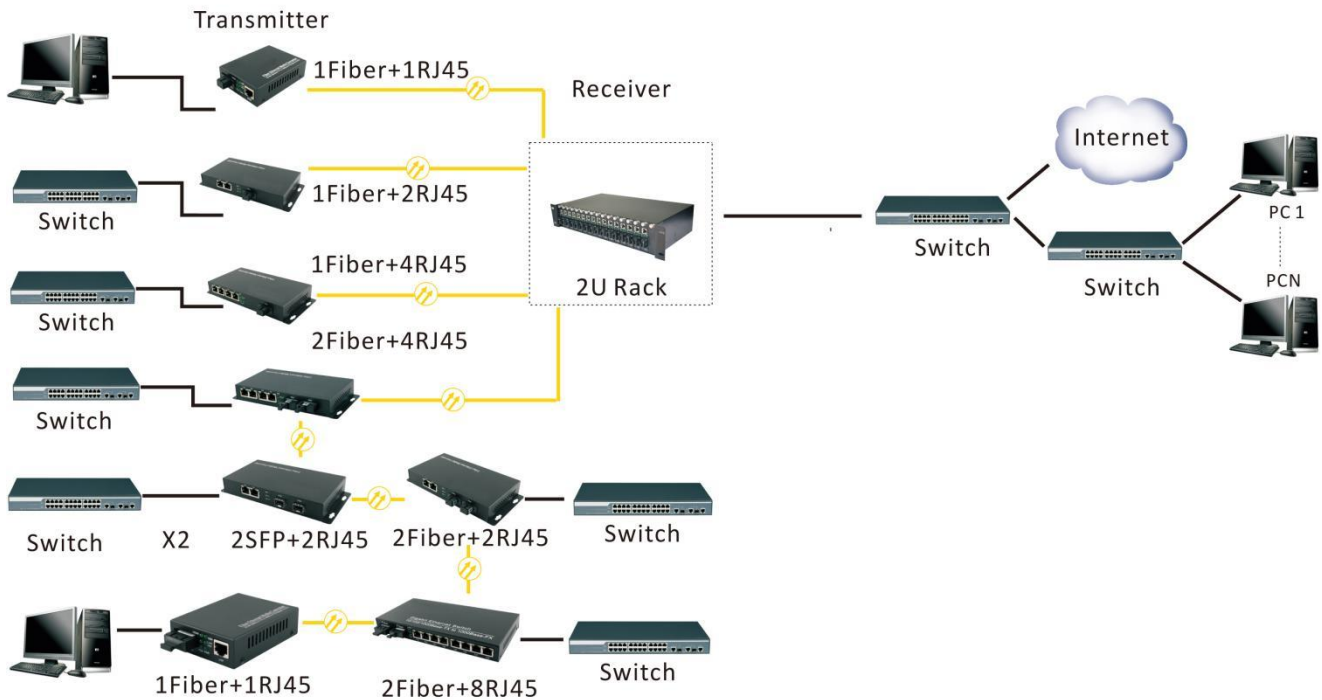

## Order Information

Part Number	Description
EMD-100-1F1R	10/100M Dual Fiber, 1Fiber and 1RJ45 ports
EMD-100-1F2R	10/100M Dual Fiber, 1Fiber and 2RJ45 ports
EMS-100-1F2R	10/100M Single Fiber, 1Fiber and 2RJ45 ports
EMD-100-1F4R	10/100M Dual Fiber, 1Fiber and 4RJ45 ports
EMS-100-1F4R	10/100M Single Fiber, 1Fiber and 4RJ45 ports
EMD-100-2F2R	10/100M Dual Fiber, 2Fiber and 2RJ45 ports
EMS-100-2F2R	10/100M Single Fiber, 2Fiber and 2RJ45 ports
EMD-100-8F2R	10/100M Dual Fiber, 8Fiber and 2RJ45 ports
EMS-100-8F2R	10/100M Single Fiber, 8Fiber and 2RJ45 ports
EMD-1100-1F2R	10/100/1000M Dual Fiber, 1Fiber and 2RJ45 ports
EMS-1100-1F2R	10/100/1000M Single Fiber, 1Fiber and 2RJ45 ports
EMD-1100-1F4R	10/100/1000M Dual Fiber, 1Fiber and 4RJ45 ports
EMS-1100-1F4R	10/100/1000M Single Fiber, 1Fiber and 4RJ45 ports
EMD-1100-1F28R	10/100/1000M Dual Fiber, 1Fiber and 8RJ45 ports
EMS-1100-1F8R	10/100/1000M Single Fiber, 1Fiber and 8RJ45 ports
EMD-1100-2F2R	10/100/1000M Dual Fiber, 2Fiber and 2RJ45 ports
EMS-1100-2F2R	10/100/1000M Single Fiber, 2Fiber and 2RJ45 ports
EMD-1100-2F4R	10/100/1000M Dual Fiber, 2Fiber and 4RJ45 ports
EMS-1100-2F4R	10/100/1000M Single Fiber, 2Fiber and 4RJ45 ports
EMD-1100-2F8R	10/100/1000M Dual Fiber, 2Fiber and 8RJ45 ports
EMS-1100-2F8R	10/100/1000M Single Fiber, 2Fiber and 8RJ45 ports

Company: ETU-Link Technology Co., LTD

Address: Right side of 3rd floor, No. 102 building, Longguan expressway, Dalang street,  
Longhua District, Shenzhen city, Guangdong Province, China 518109

Tel: +86-755 2328 4603

Addresses and phone number also have been listed at [www.etulinktechnology.com](http://www.etulinktechnology.com).

Please e-mail us at [sales@etulinktechnology.com](mailto:sales@etulinktechnology.com) or call us for assistance.